

AEROSPACE 165 DC

Specifications:

Name		HG-165AeroDC-3
DC resistance	Rdc	2,7 Ω
Nominal impedance	ZN	3 Ω
Resonance frequency	fs	49 HZ
Voice coil diameter		37 mm
Mechanical Q factor	Qms	7,1
Electrical Q factor	Qes	0,63
Total Q factor	Qts	0,58
Moving mass Mms		14,5 g
Effective piston area	Sd	135 cm²
Mechanical resistance	Rms	0,63 Kg/s
Compliance	Cms	0,73mm/N
Force factor	BL	4,4Tm
Equivalent air volume	Vas	18,5 dm³
Efficiency	η	0,33 %
SPL 2,83V/1m		92,0 dB

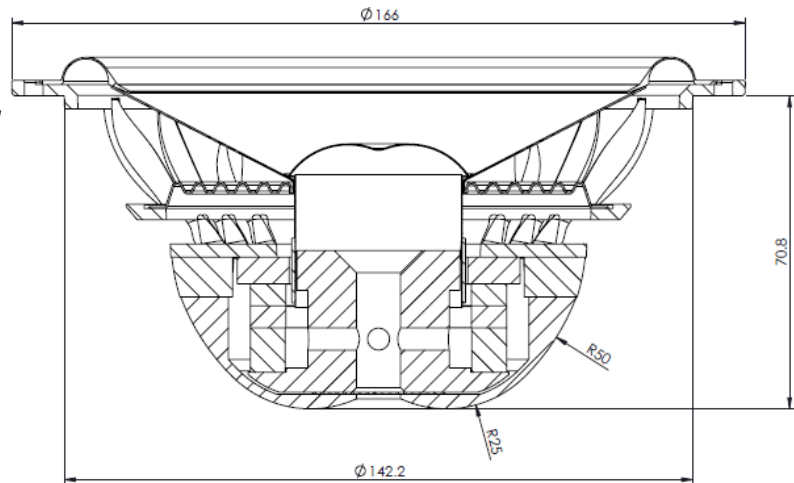

Cone:	GLADEN C7
Spider:	Connex
Surround:	SBR
Coil former:	Fibreglass
Basket:	Aluminum
Dust Cap:	Silk

