

## AEROSPACE 80 PP

### Specifications:

Name		<b>HG-80AeroPP-3</b>
DC resistance	Rdc	<b>2,5 Ω</b>
Nominal impedance	ZN	<b>3 Ω</b>
Resonance frequency	fs	<b>110 HZ</b>
Voice coil diameter		<b>25 mm</b>
Mechanical Q factor	Qms	<b>3,27</b>
Electrical Q factor	Qes	<b>0,34</b>
Total Q factor	Qts	<b>0,31</b>
Moving mass	Md	<b>3,3 g</b>
Effective piston area	Sd	<b>35 cm<sup>2</sup></b>
Mechanical resistance	Rms	<b>0,7 Kg/s</b>
Compliance	Cms	<b>0,63 mm/N</b>
Force factor	BL	<b>4,1 Tm</b>
Equivalent air volume	Vas	<b>1,1 dm<sup>3</sup></b>
Efficiency	η	<b>0,41 %</b>
SPL 2,83V/1m		<b>93,19 dB</b>
High-pass / Hochpass		<b>&gt; 300 Hz 18 dB/Oct</b> <b>&gt; 350 Hz 12 dB/Oct</b>

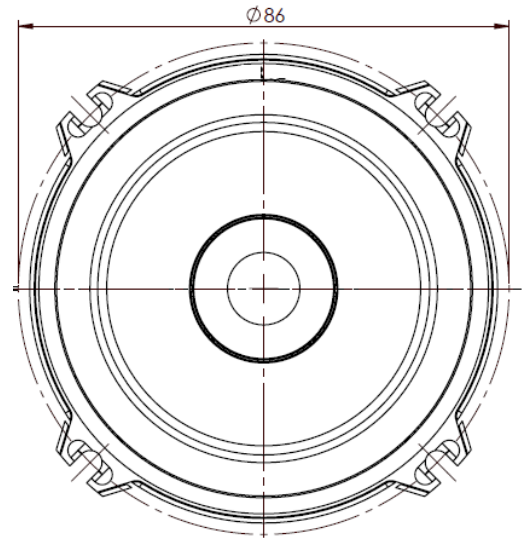
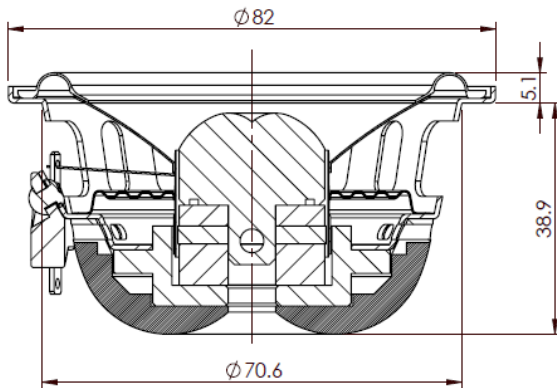

**Cone: GLADEN C5**  
**Spider: Connex**  
**Surround: SBR**  
**Coil former: Aluminum**  
**Basket: Steel**  
**Phase Plug: Aluminum**

